

#11136 PARK/PIER BENCH ASSEMBLY INSTRUCTIONS

TOOLS NEEDED:

Drill with #2 Phillips Bit or
Phillips Screwdriver
7/16" Wrenches or Sockets
File

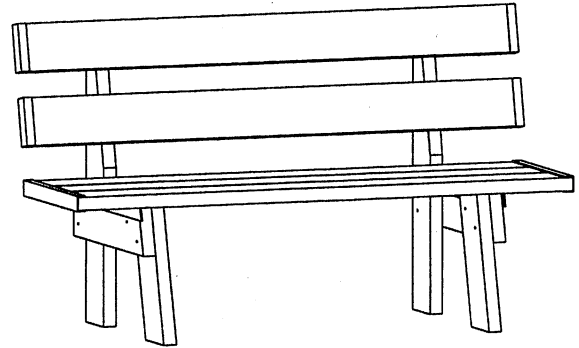

BENCH SEAT ASSEMBLY

(Refer to Upper portion of Drawing 1)

On a flat non-abrasive surface lay out the three 1 ½ x 5 ½ x 60" seat rails with screw pilot holes facing upwards (seat rails will have pilot holes in the center of the rails for center brace). Place the two seat brackets on rails as shown; fasten brackets to rails using ¾" screws. Apply glue to the inside edges of the two 7/8 x 1 ½" molded end caps on the push onto the ends of the seat brace. Lay the center brace over pilot holes in center of seat rails and fasten with 2" screws. Apply glue to the inside edges of the two 7/8 x 1 ½ x 16 ¾" seat end caps and **push** them onto the ends of the seat assembly making sure the edges are flush. (**Note: do not slide caps from ends.**) Set aside.

BENCH BACK ASSEMBLY

(Refer to Lower portion of Drawing 1) (Make 2)

Lay one of the 1 ½ x 5 ½ x 60" bench back rails with screw pilot holes facing up. Lay two of the 4" brackets over the pilot holes and fasten with ¾" screws. Apply glue to the 7/8 x 1 ½ x 5 ½" end caps and **push** one on each end of the rail. Set aside.

BENCH LEGS AND SUPPORT ASSEMBLY

(Refer to Drawing 2)

Apply glue to the inside edges of the 1 ½ x 5 5/8" angled end caps and **push** onto the front angled end of the 22" bench supports; do the same with the 1 ½ x 5 ½" end caps and **push** them onto the back ends of the bench supports.

Lay out one of the 1 ½ x 5 ½ x 22" bench supports; with angled end toward the front. Place one of the 1 ½ x 5 ½ x 18" front leg pieces on top of the bench support with the angled end and place one of the 1 ½ x 5 ½ x 34" back legs on the straight end of the bench support. Line up the bolt holes and fasten with the 3 ½" bolts, washers and nylock nut as shown. Bolt heads should be on the side of the bench support that does not have the legs. (**Note: Draw bolts up snug, but do not over tighten.**)

For opposite side; place the legs on the opposite side of the bench support. Fasten with 3 ½" bolts.

SEAT ATTACHMENT

(Refer to Drawing 3)

Lay the bench seat assembly from Drawing 1 on the edge of a table or workbench. Place the bench leg/support assemblies into the brackets as shown (make sure the bench support pieces face the outside of completed bench). Fasten each side with 2 ¼" bolts, washers and nylock nuts (bolt head should face the outside of the completed bench).

Apply glue to the end caps for the bottom of legs, using the 5 5/8" angled end caps for front legs and 5 ½" end caps for back legs. **(Note: If the Bench is being attached to a Pier or Deck with Bench Anchor Kit, DO NOT apply End Caps to bottoms of legs.)**

SEAT BACK ATTACHMENT

(Refer to Drawing 4)

Please pay close attention to order of placement.

Using one of the seat back assemblies from Drawing 1, slide the brackets over the lower part of the bench back legs. Line up the bolt holes and fasten using 2 ¼" bolts, washers and nylock nuts. Apply glue to two of the 7/8 x 1 ½ x 4" end caps and place above the lower seat rail. Make sure the end caps are tight against the brackets of the lower seat back assembly. Place the second seat back assembly above the ends, line up bolt holes and fasten as above. Apply glue carefully to the 3/8 x 1 ½ x 2" end caps from hardware bag and place on top of the back legs.

Upon completion of bench be sure to file or sand any sharp edges on the end caps to prevent cuts and scrapes.

If you encounter missing or defective parts, please contact manufacturer direct at toll free # below.

VINYL LAWN & GARDEN PRODUCTS

Please call manufacturer direct with questions concerning missing or defective parts at Toll Free: 877-258-6020.

Dura-Trel, Inc. products are warranted to be free from manufacturing defects resulting in delaminating, peeling, flaking, corroding, cracking, crazing, or extreme amounts of fading or bleaching causing the PVC to change to its natural color for a period of 20 years from the date of purchase.

Normal Weathering is defined as exposure to sunlight and extremes of weather and atmosphere which will cause any colored surface to gradually fade.

CONDITIONS NOT COVERED BY THIS WARRANTY:

- A. Physical abuse, misuse, neglect, or improper storage.
- B. Improper installation or installation not in strict adherence to instructions written by Dura-Trel, Inc.
- C. This warranty does not apply if materials are painted, varnished or coated with any substance.
- D. Dura-Trel, Inc. is not responsible for damages to product during shipping.
- E. Damage attributable to atmospheric pollutants, hail, lightning, hurricane, tornado, wind borne objects, earthquake, fire, mildew, casualty, act of God, building or ground settlement, or subjection to stress or weight.

CLAIMS AND REMEDIES:

If a Dura-Trel, Inc. product is determined to have a manufacturing defect which is covered by this warranty, Dura-Trel will replace the material containing the defect (labor not included) F.O.B from the point of manufacture.

Dura-Trel, Inc. will not be responsible for any cost incurred in the removal or reinstallation of the product.

Important: Any claims under this warranty must be made within 30 days after the defect was first discovered or reasonably could have been discovered.

All warranty claims must be sent to the following address and should describe the defect claim.

Dura-Trel, Inc., P.O. Box 122, Sheboygan Falls, WI 53085

Dura-Trel, Inc. reserves the right to discontinue or change its design, and or color. If the original color or style is not available, Dura-Trel, Inc. shall have the right to substitute a product designated by Dura-Trel, Inc.

Dura-Trel, Inc. shall not be liable for any incidental, special, or consequential damages arising out of the use of these products.

20 Y R W a r r a n t y

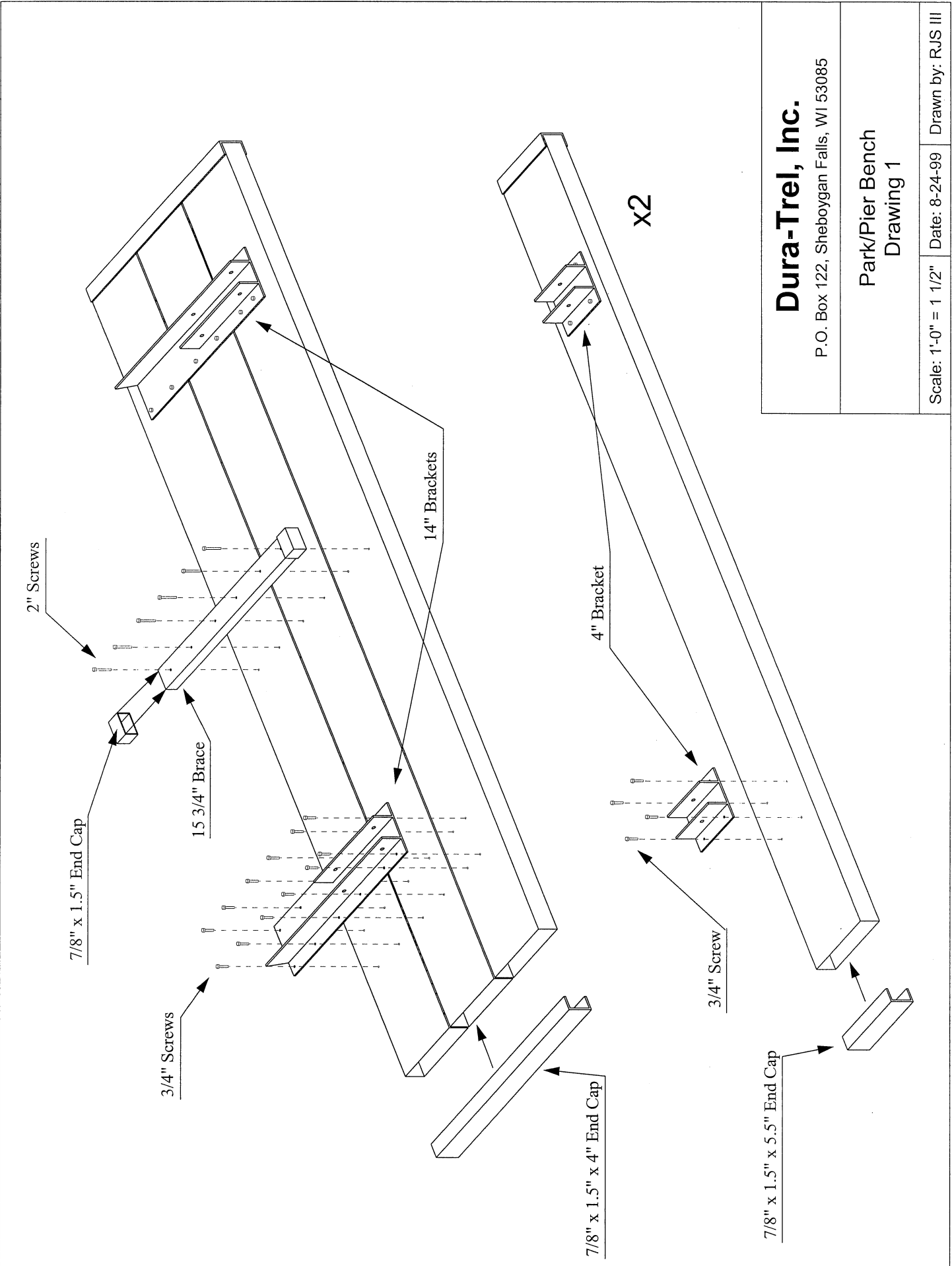

Dura-Trel, Inc.

P.O. Box 122, Sheboygan Falls, WI 53085

**Park/Pier Bench
Drawing 1**

Scale: 1'-0" = 1 1/2" Date: 8-24-99 Drawn by: RJS III

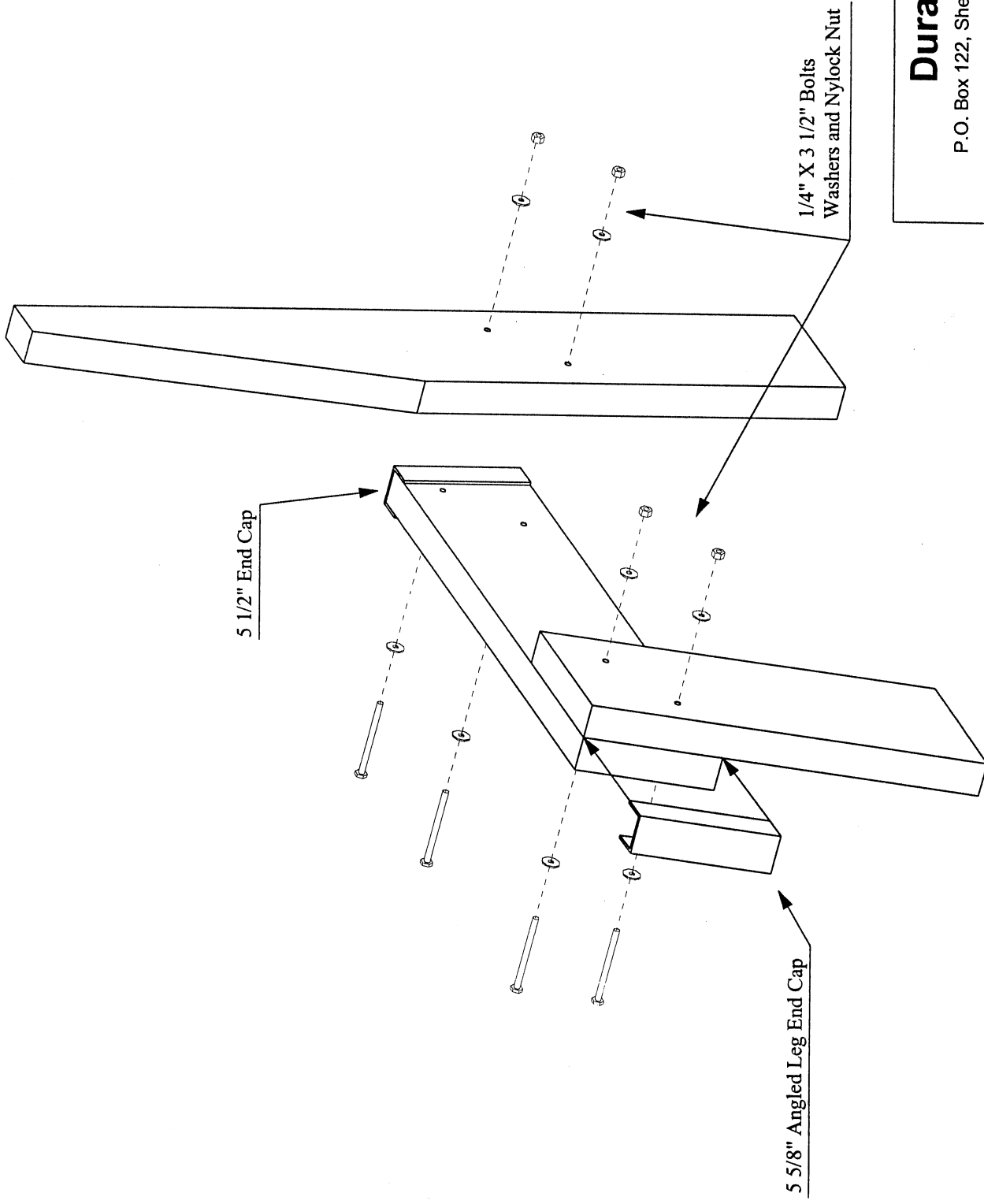

5 1/2" End Cap

5 5/8" Angled Leg End Cap

1/4" X 3 1/2" Bolts
Washers and Nylock Nut

Note: Repeat for opposite side,
placing the support on opposite
side of legs.

Dura-trel, Inc.

P.O. Box 122, Sheboygan Falls, WI 53085

**Park/Pier Bench
Drawing 2**

Scale: 1'-0" = 2"

Date: 8-24-99

Drawn by: RJS III

7/8" x 1.5 x 5 5/8" Angled Leg End Cap

7/8" x 1.5 x 5.5" End Cap

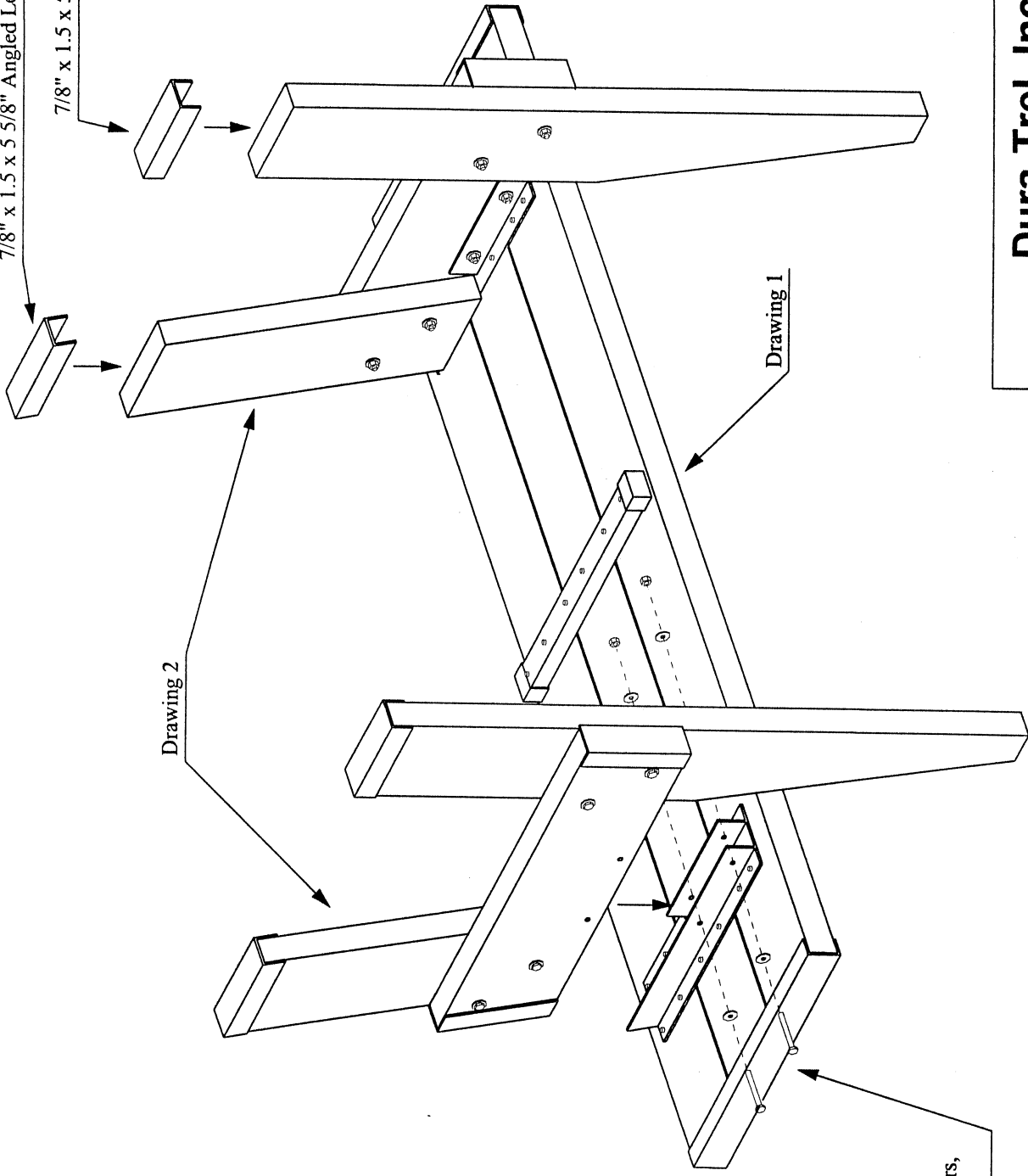

Drawing 2

Drawing 1

2 1/4" Bolts, Washers,
and Nylock Nuts

Dura-Trel, Inc.

P.O. Box 122, Sheboygan Falls, WI 53085

Park/Pier Bench
Drawing 3

Note: If Bench is being used
with Bench Anchor Kit, Do
NOT apply caps to bottom of
legs

Scale: 1'-0" = 1 1/2" Date: 8-24-99 Drawn by: RJS III

2 1/4" Bolts, Washers,
and Nylock Nuts

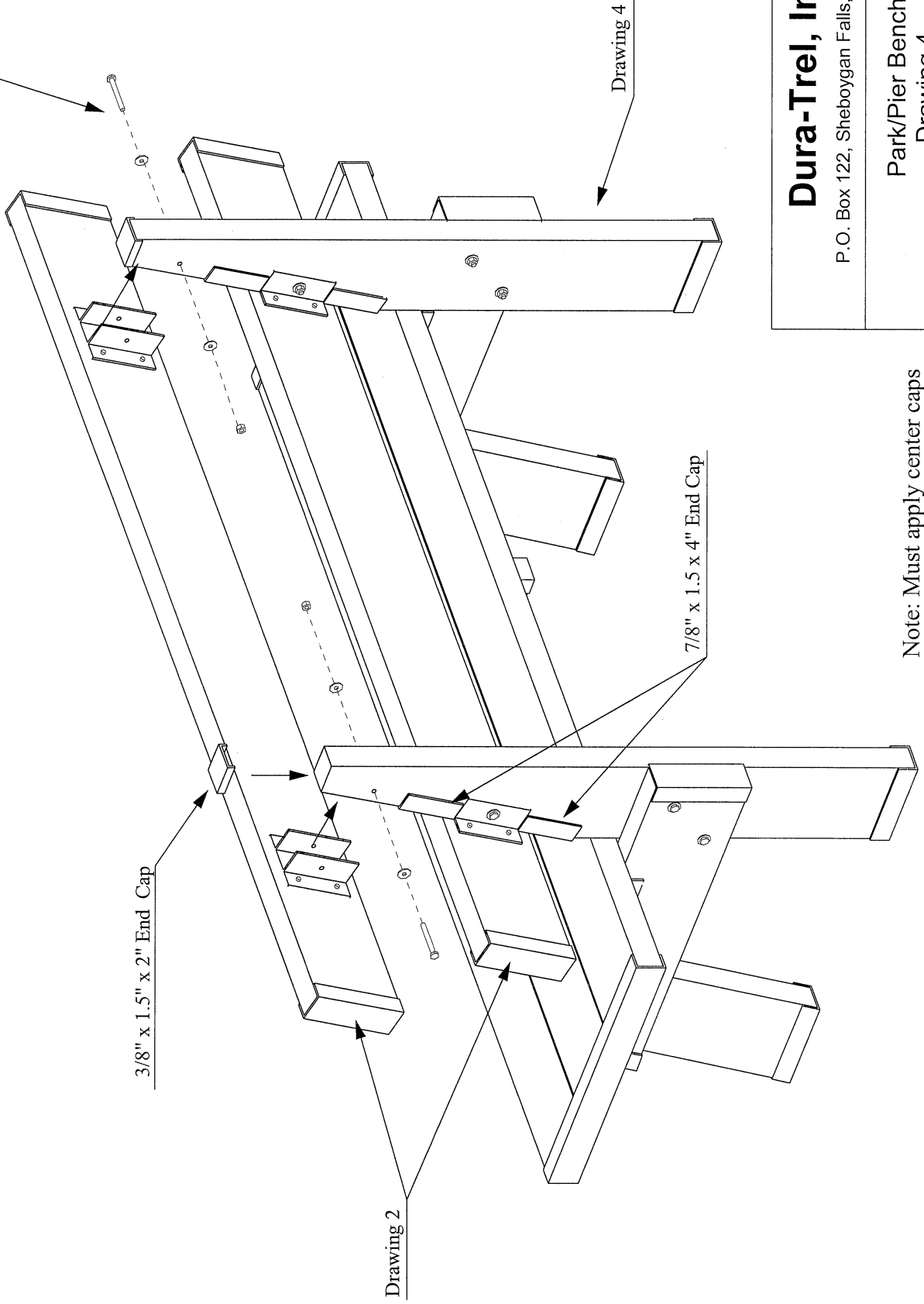

Drawing 4

7/8" x 1.5 x 4" End Cap

3/8" x 1.5" x 2" End Cap

Drawing 2

Dura-Trel, Inc.

P.O. Box 122, Sheboygan Falls, WI 53085

Park/Pier Bench Drawing 4

Note: Must apply center caps
before attaching top back rail.

Scale: 1'-0" = 1 1/2"

Date: 8-24-99

Drawn by: RJS III

PACKING LIST

#11136 PARK/PIER BENCH

PARTS CONTAINED:

QTY.	PART NO.	PART DESCRIPTION
3	41555-60001	1½ x 5½ x 60" SEAT RAIL
2	41555-60002	1½ x 5½ x 60" BACK RAIL
2	41555-34001	1½ x 5½ x 34" ANGLED BACK LEG
2	41555-16000	1½ x 5½ x 16" FRONT LEG
2	41555-22500	1½ x 5½ x 22½" BENCH SUPPORT
1	4TBCK-14500L	14½" LEFT BRACKET
1	4TBCK-14500R	14½" RIGHT BRACKET
4	4TBCK-04000	4" SEAT BACK BRACKET
1	47815-15750	7/8 x 1½ x 15¾" SEAT BRACE
2	5ECAP-16750	7/8 x 1½ x 16¾" SEAT END CAP
4	5ECAP-05580	7/8 x 1½ x 5⅝" ANGLED END CAP
8	5ECAP-05500	7/8 x 1½ x 5½" END CAP
1	7GLUE-4OZCN	4 oz PVC GLUE CAN
		Hardware Bag Includes:
4	5ECAP-04000	7/8 x 1½ x 4" SEAT BACK END CAP
2	5ECAP-02000	3/8 x 1 ½ x 2" TOP SEAT BACK END CAP
2	5ECAP-7815E	7/8 x 1 ½" END CAPS
40	7HDWR-06034	¾" SCREW
6	7HDWR-06200	2" SCREW
8	7HDWR-14350	¼ x 3 ½" BOLT
8	7HDWR-14225	¼ x 2 ¼" BOLT
16	7HDWR-14NUT	¼" NYLOCK NUT
32	7HDWR-14WSH	¼" FLAT WASHER
1		PARK/PIER BENCH INSTRUCTIONS

NOTE: Some parts may be packed inside of others.

If you encounter missing or defective parts, please contact manufacturer direct at toll free # below.