

## #11130 PLANTER SEAT ASSEMBLY INSTRUCTIONS

### TOOLS NEEDED

Drill with #2 Phillips Bit or  
Phillips Screwdriver  
Household Glue (optional)

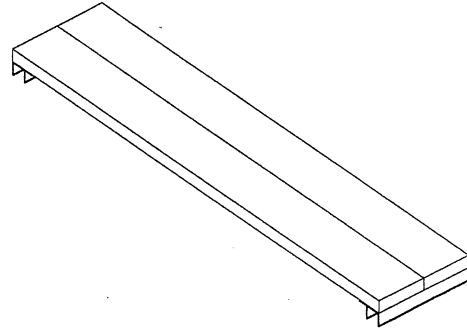

### SEAT ASSEMBLY

(Refer to Drawing 1)

Lay the two 48" seat rails on clean, flat surface with pilot holes facing up. Set the brackets over pilot holes in rails, with the flanged side of the bracket toward center of seat. Fasten brackets to seat rails with  $\frac{3}{4}$ " screws. Slide end caps over ends of seat, end caps will slide between bracket and rails. You may apply household glue to inside of end cap if needed.

Place planter seat between two planter boxes by setting brackets over the edge of both planters.

If you encounter missing or defective parts, please contact manufacturer direct at  
toll free # below.

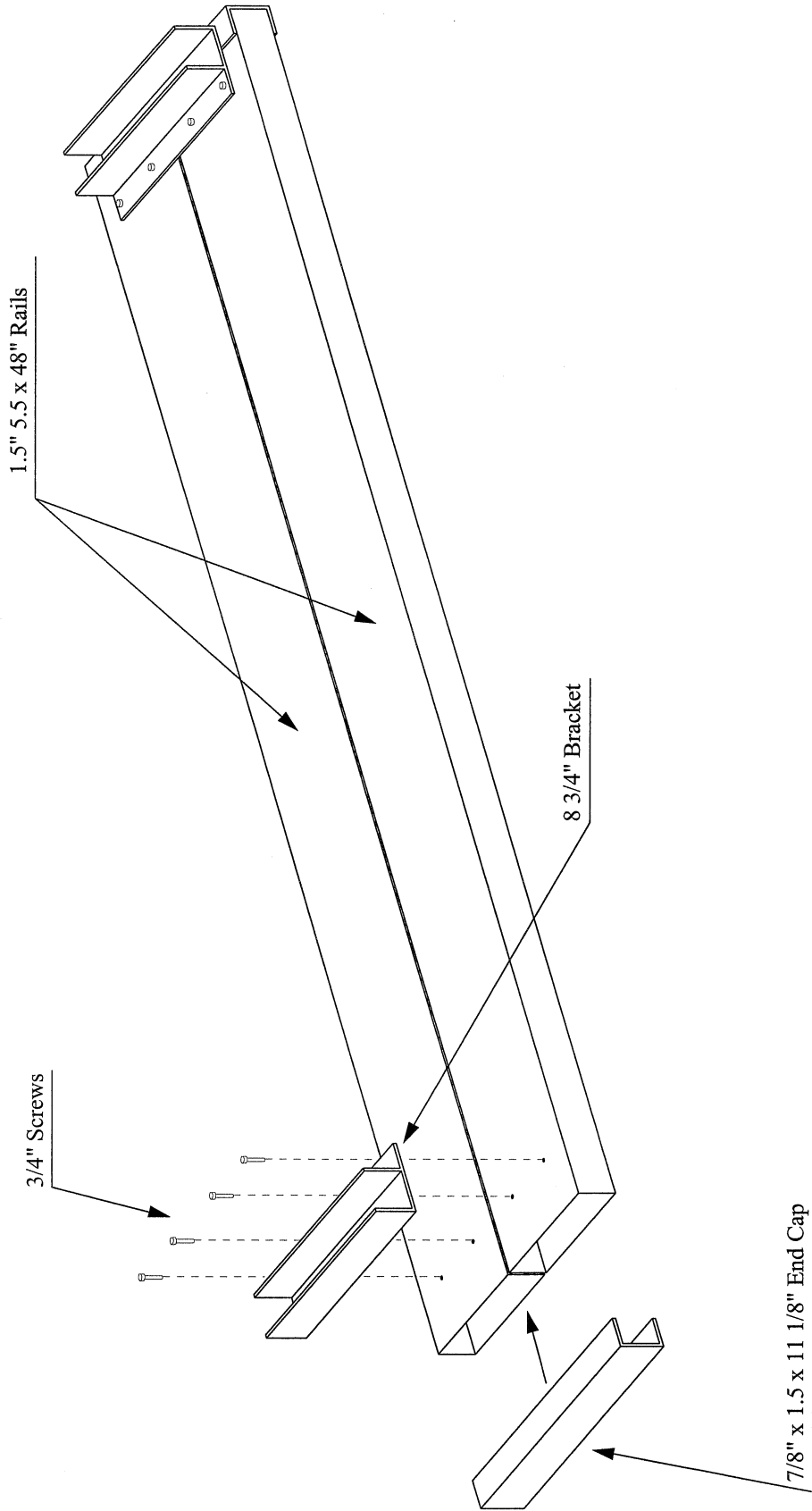

**Dura-Trel, Inc.**

P.O. Box 122, Sheboygan Falls, WI 53085

Planter Seat  
Drawing 1

Scale: 1'-0" = 2"

Date: 6-17-99

Drawn by: RJS III

## PACKING LIST

**#11130    PLANTER SEAT**

**PARTS CONTAINED:**

QTY.	PART NO.	PART DESCRIPTION
2	41555-48003W	1½ x 5½ x 48" SEAT RAIL (w/ wood inserts)
2	4TBCK-08752	8¾" BRACKET
2	5ECAP-11180	7/8 x 1½ x 11½" END CAP
		<b>Hardware Bag Includes:</b>
8	7HDWR-06034	¾" SCREW
1		PLANTER SEAT INSTRUCTION

**NOTE:** Some parts may be packed inside of others.

If you encounter missing or defective parts, please contact manufacturer direct at toll free # below.

---

VINYL LAWN & GARDEN PRODUCTS

---

*Please call manufacturer direct with questions concerning missing or defective parts at Toll Free: 877-258-6020.*

Dura-Trel, Inc. products are warranted to be free from manufacturing defects resulting in delaminating, peeling, flaking corroding, cracking, crazing, or extreme amounts of fading or bleaching causing the PVC to change to its natural color for a period of 20 years from the date of purchase.

*Normal Weathering is defined as exposure to sunlight and extremes of weather and atmosphere which will cause any colored surface to gradually fade.*

**CONDITIONS NOT COVERED BY THIS WARRANTY:**

- A. Physical abuse, misuse, neglect, or improper storage.
- B. Improper installation or installation not in strict adherence to instructions written by Dura-Trel, Inc.
- C. This warranty does not apply if materials are painted, varnished or coated with any substance.
- D. Dura-Trel, Inc. is not responsible for damages to product during shipping.
- E. Damage attributable to atmospheric pollutants, hail, lightning, hurricane, tornado, wind borne objects, earthquake, fire, mildew, casualty, act of God, building or ground settlement, or subjection to stress or weight.

**CLAIMS AND REMEDIES:**

If a Dura-Trel, Inc. product is determined to have a manufacturing defect which is covered by this warranty, Dura-Trel will replace the material containing the defect (labor not included) F.O.B from the point of manufacture.

Dura-Trel, Inc. will not be responsible for any cost incurred in the removal or reinstallation of the product.

**Important:** Any claims under this warranty must be made within 30 days after the defect was first discovered or reasonably could have been discovered.

All warranty claims must be sent to the following address and should describe the defect claim.

**Dura-Trel, Inc., P.O. Box 122, Sheboygan Falls, WI 53085**

Dura-Trel, Inc. reserves the right to discontinue or change its design, and or color. If the original color or style is not available, Dura-Trel, Inc. shall have the right to substitute a product designated by Dura-Trel, Inc.

Dura-Trel, Inc. shall not be liable for any incidental, special, or consequential damages arising out of the use of these products.

---

## 20 Y R W a r r a n t y

---