



Elmwood Arbor

Model# 11199 (M) Assembly Instructions

General Information

PLEASE READ THROUGH BEFORE BEGINNING ASSEMBLY.

IMPORTANT: Check boxes for Contents Listed

Check inside of parts as some parts are packaged inside of others

In the event of missing, damaged or defective parts please call our customer service dept. at 1-877-258-6020

When assembling components, place on a clean, flat non-abrasive surface to avoid scratches

Tools Required

- ... Battery or Electric Drill with #2 phillips bit
- ... Tape Measure
- ... Hammer or Rubber Mallet (recommended)

<u>Part #</u>	<u>Description</u>	<u>Qty</u>
1	2" sq. x 84" Left Post	2
2	2" sq. x 84" Right Post	2
3	7/8 x 1 1/2 x 22" Top/Bottom Cross Rail	4
4	1/4 x 1 1/2 x 56 3/4" Vertical Slat	4
5	1/4 x 1 1/2 x 22" Horizontal Slat	12
6	7/8 x 3 x 56 3/4" Arbor Top Rail	2
7	7/8 x 3 x 19 1/2" Arbor Top Cross Rail	2
8	1/4 x 1 1/2 x 44 1/2" Arbor Top Slat	2
9	1/4 x 1 1/2 x 21" Arbor Top Cross Slat	5
10	1/4 x 1 1/2 x 16 1/2" Corner Brace	4
11	Hardware Bag (includes:)	1
	2" sq." Post Cap	4
	7/8 x 3" Arbor Top Cap	4
	1 1/2" Painted Screw	20
	3/4" Painted Screw	4
	Super Glue Tube	1
12	Arbor Ground Anchor Kit (includes:)	1
	16" Steel Ground Anchor (L-Shaped)	4
	#8 - 1" Painted Self Tapping Screw	8

Warranty Statement

20 Year Guarantee

Please call manufacturer direct with questions concerning missing or defective parts at Toll Free: 877-258-6020.

Dura-trel, Inc. products are warranted to be free from manufacturing defects resulting in delaminating, peeling, flaking, corroding, cracking, crazing, or extreme amounts of fading or bleaching causing the PVC to change to its natural color for a period of 20 years from the date of purchase.

Normal weathering is defined as exposure to sunlight and extremes of weather and atmosphere which will cause any colored surface to gradually fade.

CONDITIONS NOT COVERED BY THIS WARRANTY:

- A. Physical abuse, misuse, neglect, or improper storage.
- B. Improper installation or installation not in strict adherence to the instructions written by Dura-Trel, Inc.
- C. This warranty does not apply if materials are painted, varnished, or coated with any substance.
- D. Dura-Trel, Inc. is not responsible for damages to product during shipping.
- E. Damage attributable to atmospheric pollutants, hail, lightning, hurricane, tornado, wind borne objects, earthquake, fire, mildew, casualty, act of God, building or ground settlement, or subjection to stress or weight.

CLAIMS AND REMEDIES:

If a Dura-Trel, Inc. product is determined to have a manufacturing defect which is covered by this warranty, Dura-Trel, Inc. will replace the material containing the defect (labor not included) F.O.B from the point of manufacture. Dura-trel, Inc. will not be responsible for any cost incurred in the removal or reinstallation of the product.

Important: An claims must be sent to the following address and should describe the defect claim.

Dura-Trel, Inc., P.O. Box 122, Sheboygan Falls, WI 53085

Dura-Trel, Inc. reserves the right to discontinue or change its design, and or color. If the original color or style is not available, Dura-Trel, Inc. shall have the right to substitute a product designated by Dura-Trel, Inc.

Dura-Trel, Inc. shall not be liable for any incidental, special, or consequential damages arising out of the use of these products

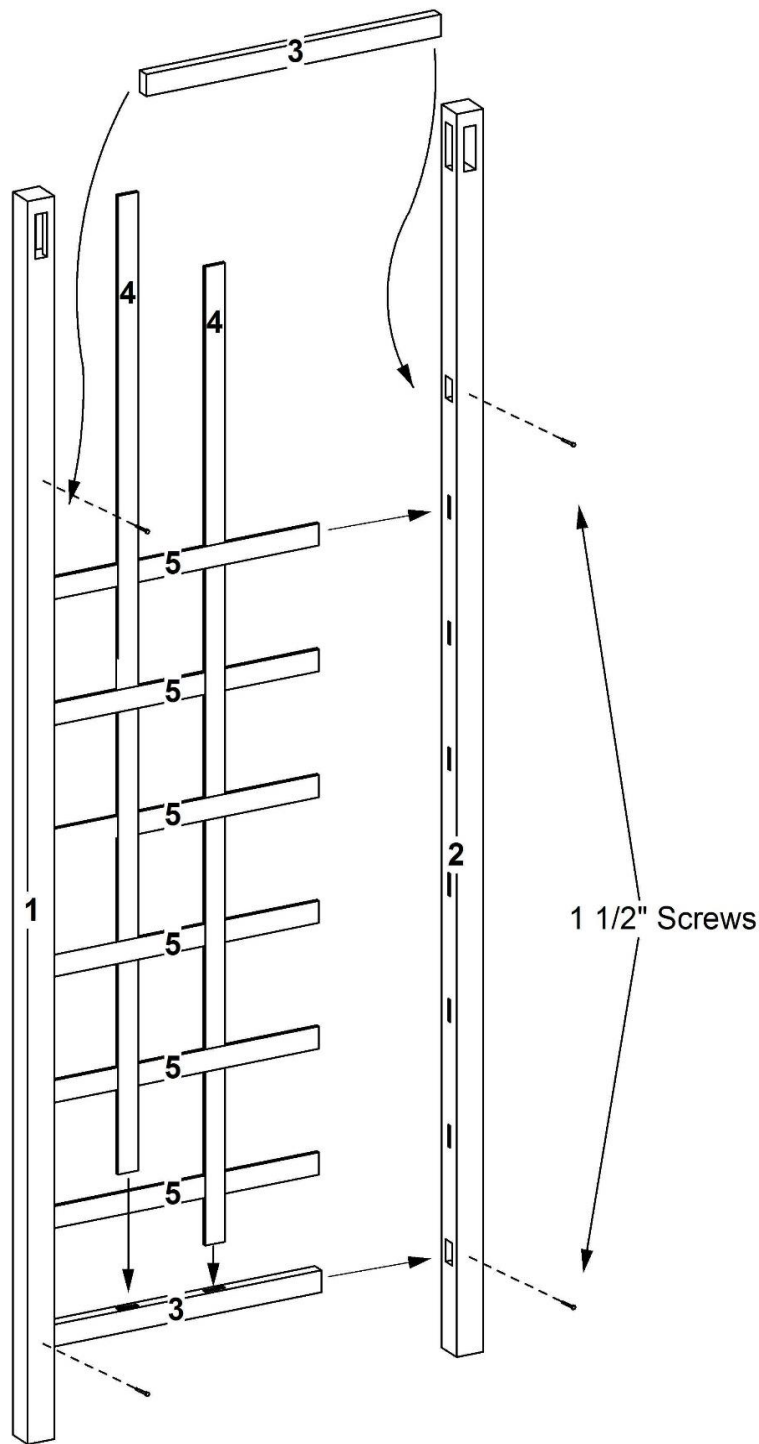

Lay out one 84" one left post (part 1). Starting at bottom, insert one 22" top/bottom cross rail (part 3) and six 22" horizontal slat (part 5). Insert free ends of bottom cross rail and horizontal slats into one 84" right post (part 2). Weave one 56 $\frac{3}{4}$ " vertical slat (part 4) through horizontal slats. Insert end into left hole of bottom cross rail. Weave remaining second 56 $\frac{3}{4}$ " vertical slat (part 4) through horizontal slats opposite of left vertical slat. Insert end into right hole of bottom cross rail. Separate tops of posts just enough to insert remaining 22" top/bottom cross rail (part 3).

Using two 1 $\frac{1}{4}$ " screws per post, fasten together arbor panel. Be sure all parts are fully inserted into posts before fastening. REPEAT using remaining posts, top/bottom cross rails, horizontal and vertical slats to assemble second arbor panel.

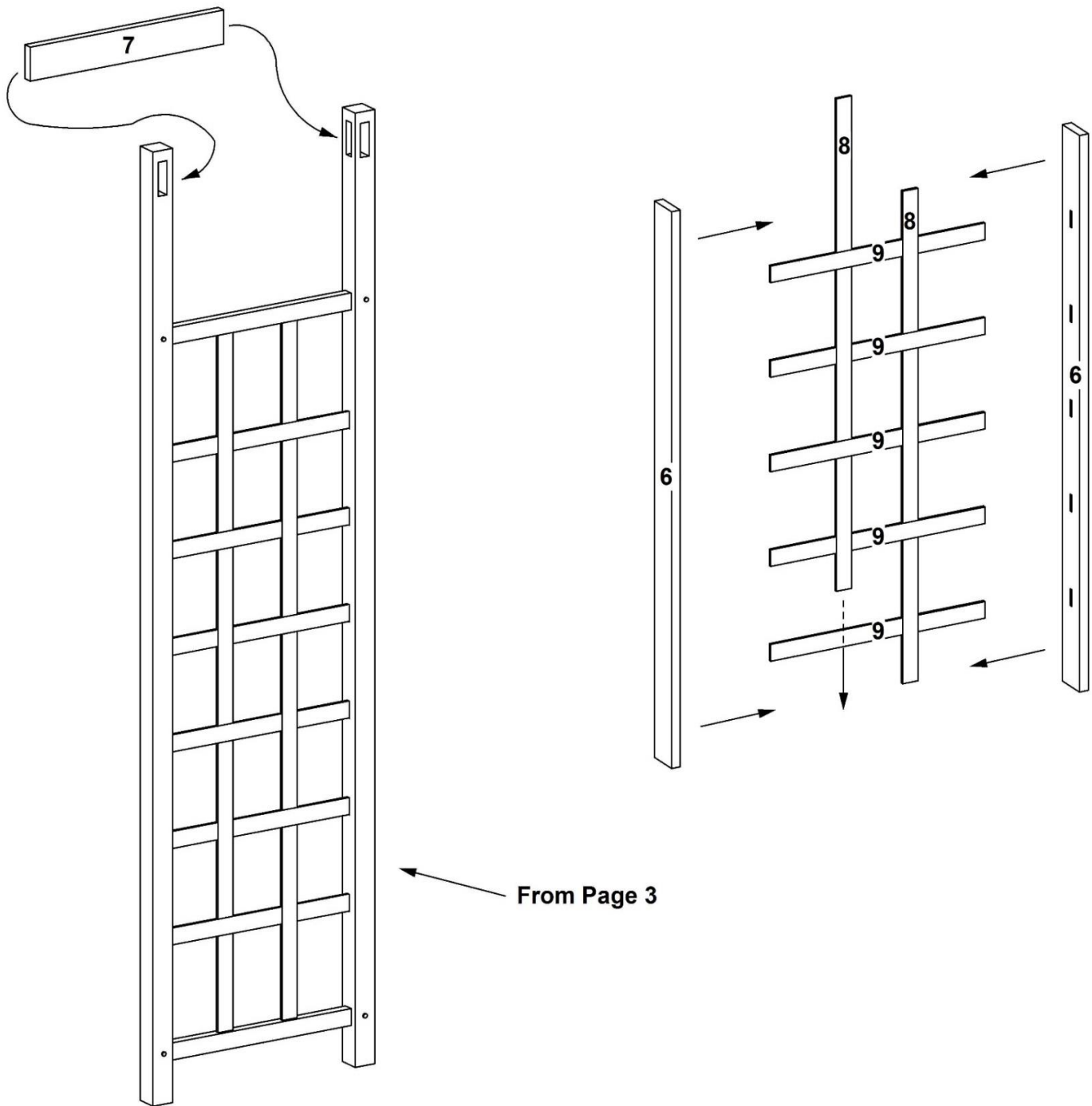

Insert one 19½" arbor top cross rail (part 7) into top holes of both assembled arbor panels (from page 3.) Center arbor top cross rail between posts to allow parts to be inserted through the remaining routed holes.

Insert five 21" arbor top cross slats (part 9) into one 56¾" arbor top rail (part 6). Insert free ends of arbor top cross slats into remaining 56¾" arbor top rails (part 6). Weave one 44½" arbor top slat (part 8) through arbor top cross slats. Weave remaining 44½" arbor top slat (part 8) through arbor top cross slats opposite of other arbor top slat.

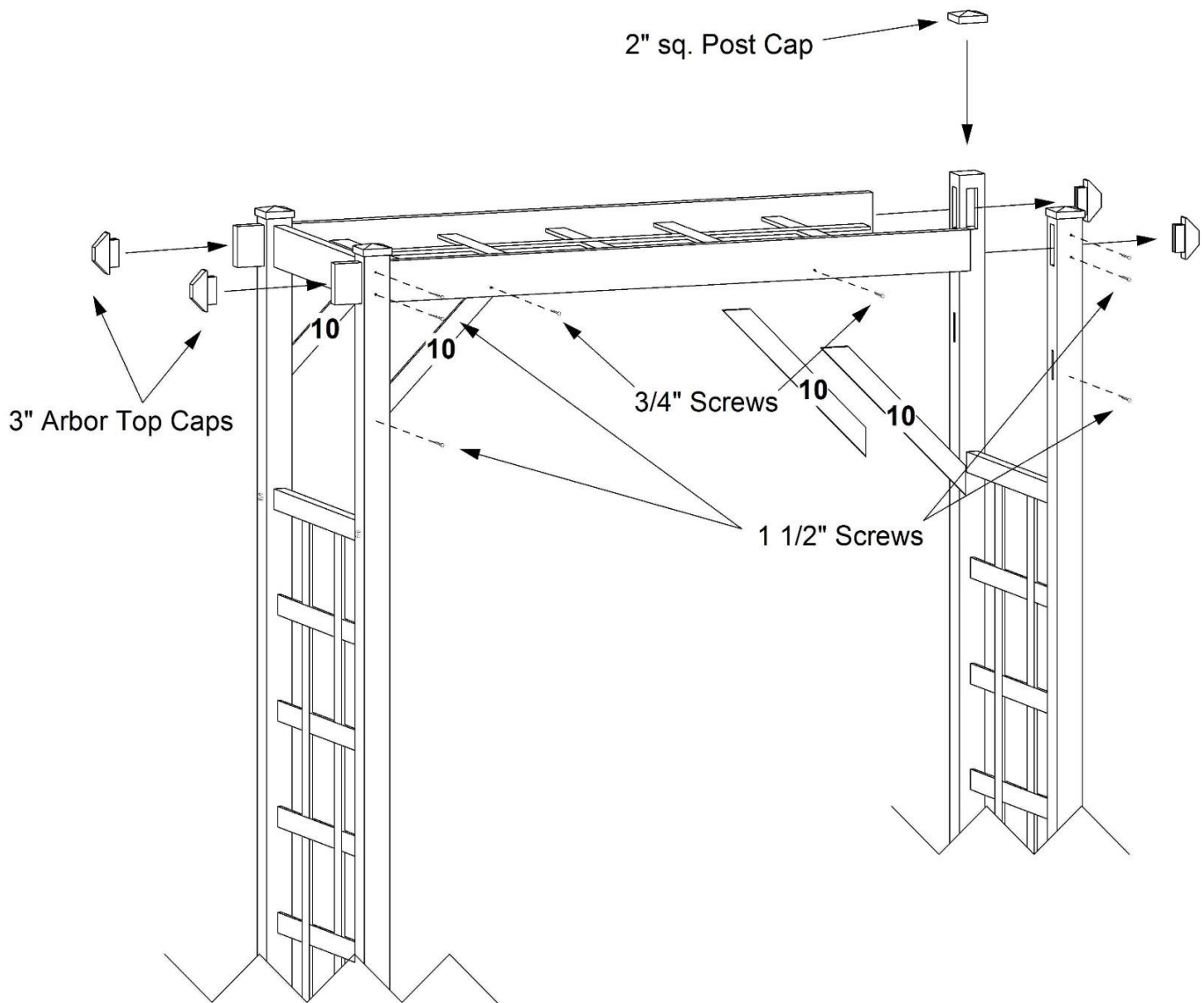

Insert two 16½" corner braces (part 10) into each 56¾" arbor top (from page 4). Slide ends of arbor top rail through holes at top of post, inserting corner braces into posts and free ends of 44½" arbor top slats into corresponding holes of 19½" arbor top cross rails. Using three 1½" screws per post, fasten together posts, arbor top rails and corner braces. Using four total ¾" screws, fasten corner braces to arbor top rails.

Using included super glue tube, glue ¾ x 3" arbor top end caps onto ends of each arbor top cross rail. Glue four 2" sq. post caps onto tops of post.

11199	Elmwood Arbor	
1	2" sq. x 84" EWA Left Post	2.00
2	2" sq. x 84" EWA Right Post	2.00
3	$\frac{7}{8}$ x $1\frac{1}{2}$ x 22" PVT Top/Bottom	4.00
4	$\frac{1}{4}$ x $1\frac{1}{2}$ x $56\frac{3}{4}$ " Slat	4.00
5	$\frac{1}{4}$ x $1\frac{1}{2}$ x 22" Slat	12.00
6	$\frac{7}{8}$ x 3 x $56\frac{3}{4}$ " CBA Arbor Top	2.00
7	$\frac{7}{8}$ x 3 x $19\frac{1}{2}$ " EWA Top Cross	2.00
8	$\frac{1}{4}$ x $1\frac{1}{2}$ x $44\frac{1}{2}$ " Slat	2.00
9	$\frac{1}{4}$ x $1\frac{1}{2}$ x 21" Slat	5.00
10	$\frac{1}{4}$ x $1\frac{1}{2}$ x $16\frac{1}{2}$ " Slat	4.00
11	Hardware Bag	1.00
	2" sq." Post Cap	4.00
	$\frac{7}{8}$ x 3" Dog Ear Picket Cap	4.00
	$1\frac{1}{2}$ " Painted Screw	28.00
	$\frac{3}{4}$ " Painted Screw	4.00
	Super Glue Tube	1.00
	Grnd Anch - Arbor (2 x 2)	1.00
	#8 - 1" Self Tapping White He	8.00