



8' Picnic Table

Model# 11116

Assembly Instructions

Part #	Description	Box#	Qty
1	1½ x 5½ x 94" Table Rail	1	2
2	1½ x 5½ x 94" Seat Rail	2/3	4
3	1½ x 5½ x 59½" Cross Brace	2	2
4	1½ x 5½ x 30¼" Leg	2/3	4
5	25½" Table Bracket	3	2
6	8¾" Seat Bracket	3	4
7	⅞ x 1½ x 27" Center Brace	3	1
8	⅞ x 1½ x 33½" Diagonal Brace	3	2
9	28" Table End Cap	3	2
10	11 ⅞" Seat End Cap	3	4
11	6 ⅞" Leg End Cap	3	4
12	5½" Cross Brace End Cap	3	4
13	Hardware Bag (includes:)	3	1
	⅞ x 1½" End Cap		2
	¾" Screw		72
	1½" Screw		12
	¼ x 3½" Bolt		8
	¼ x 2¼" Bolt		18
	¼" Nylock Nut		26
	¼" Flat Washer		52
	Super Glue Tube		2

General Information

PLEASE READ THROUGH BEFORE BEGINNING ASSEMBLY.

IMPORTANT: Check boxes for Contents Listed

Check inside of parts as some parts are packaged inside of others

In the event of missing, damaged or defective parts please call our customer service dept. at 1-877-258-6020

When assembling components, place on a clean, flat non-abrasive surface to avoid scratches

Tools Required

- ... Battery or Electric Drill with #2 phillips bit, ¼", ⅝" drill bits
- ... Two 7/16" wrenches or sockets
- ... Tape Measure
- ... File



115 Vision Parkway
P.O. Box 122
Sheboygan Falls, WI 53085

1-877-258-6020
www.dura-trel.com
sales@dura-trel.com

Warranty Statement

20 Year Guarantee

Please call manufacturer direct with questions concerning missing or defective parts at Toll Free: 877-258-6020.

Dura-trel, Inc. products are warranted to be free from manufacturing defects resulting in delaminating, peeling, flaking, corroding, cracking, crazing, or extreme amounts of fading or bleaching causing the PVC to change to its natural color for a period of 20 years from the date of purchase.

Normal weathering is defined as exposure to sunlight and extremes of weather and atmosphere which will cause any colored surface to gradually fade.

CONDITIONS NOT COVERED BY THIS WARRANTY:

- A. Physical abuse, misuse, neglect, or improper storage.
- B. Improper installation or installation not in strict adherence to the instructions written by Dura-Trel, Inc.
- C. This warranty does not apply if materials are painted, varnished, or coated with any substance.
- D. Dura-Trel, Inc. is not responsible for damages to product during shipping.
- E. Damage attributable to atmospheric pollutants, hail, lightning, hurricane, tornado, wind borne objects, earthquake, fire, mildew, casualty, act of God, building or ground settlement, or subjection to stress or weight.

CLAIMS AND REMEDIES:

If a Dura-Trel, Inc. product is determined to have a manufacturing defect which is covered by this warranty, Dura-Trel, Inc. will replace the material containing the defect (labor not included) F.O.B from the point of manufacture. Dura-trel, Inc. will not be responsible for any cost incurred in the removal or reinstallation of the product.

Important: An claims must be sent to the following address and should describe the defect claim.

Dura-Trel, Inc., P.O. Box 122, Sheboygan Falls, WI 53085

Dura-Trel, Inc. reserves the right to discontinue or change its design, and or color. If the original color or style is not available, Dura-Trel, Inc. shall have the right to substitute a product designated by Dura-Trel, Inc.

Dura-Trel, Inc. shall not be liable for any incidental, special, or consequential damages arising out of the use of these products



115 Vision Parkway

P.O. Box 122

Sheboygan Falls, WI 53085

1-877-258-6020

www.dura-trel.com

sales@dura-trel.com

2

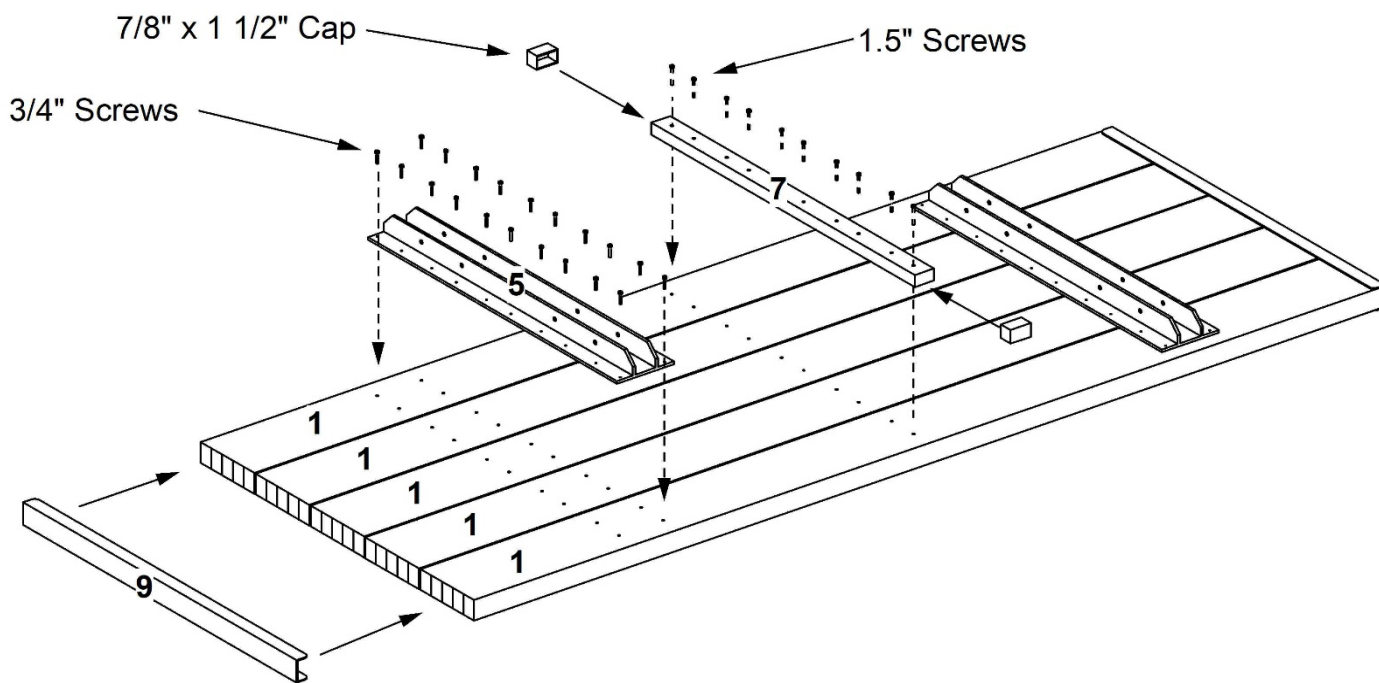
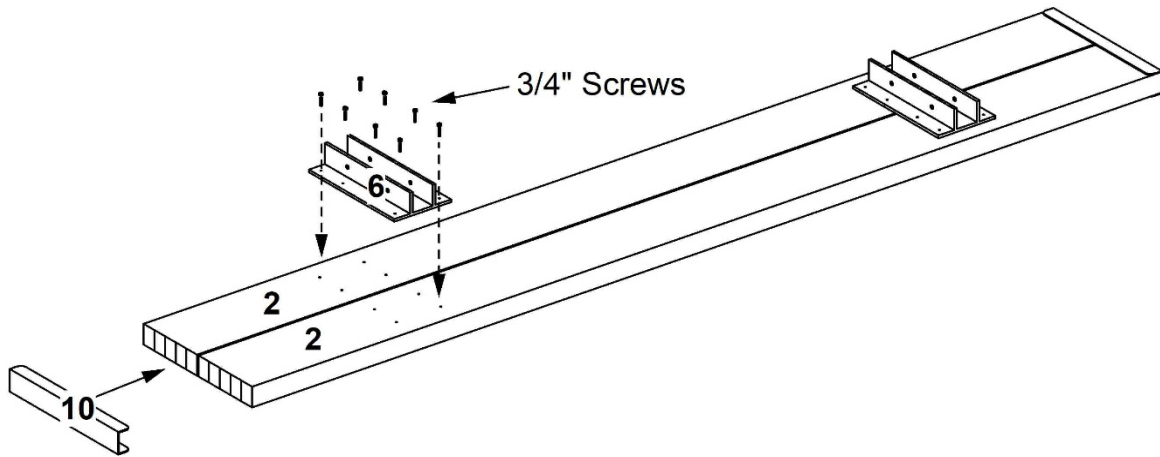

TABLE TOP ASSEMBLY

Lay out five 94" table top rails (part 1) as shown above with pilot holes facing up. Table top rails have two holes in the center of each rail, seat rails do not. Set two 25½" table brackets (part 5) over pilot holes at each end of table top rail, leaving ⅛" gap between rails. Using twenty ¾" screws per bracket, fasten each bracket to table top rails.

Apply glue to inner edges of ⅞ x 1½" end cap (from hardware bag) and press on each end of 27" center brace (part 7). Set center brace over pilot holes in center of table top. Using ten 1½" screws, fasten center brace to table top.

Apply glue to inside edges of 28" table top end cap (part 9). Press end cap onto ends of table top (DO NOT slide from end). Take care that end cap is flush with ends of table and use a file to round off any sharp edges.



SEAT ASSEMBLY

Lay out two 94" seat rails (part 2) with pilot holes facing up. Seat rails do not have any holes in the center of each rail. Set two 8³/₄" seat brackets (part 6) over pilot holes at each end of seat rail, leaving 1/8" gap between rails. Using eight 3/4" screws per bracket, fasten each bracket to seat rails.

Apply glue to inside edges of 11¹/₈" seat end cap (part 10). Press end cap onto ends of seat (DO NOT slide from end). Take care that end cap is flush with ends of seat and use a file to round off any sharp edges.

Repeat to assembly second seat.

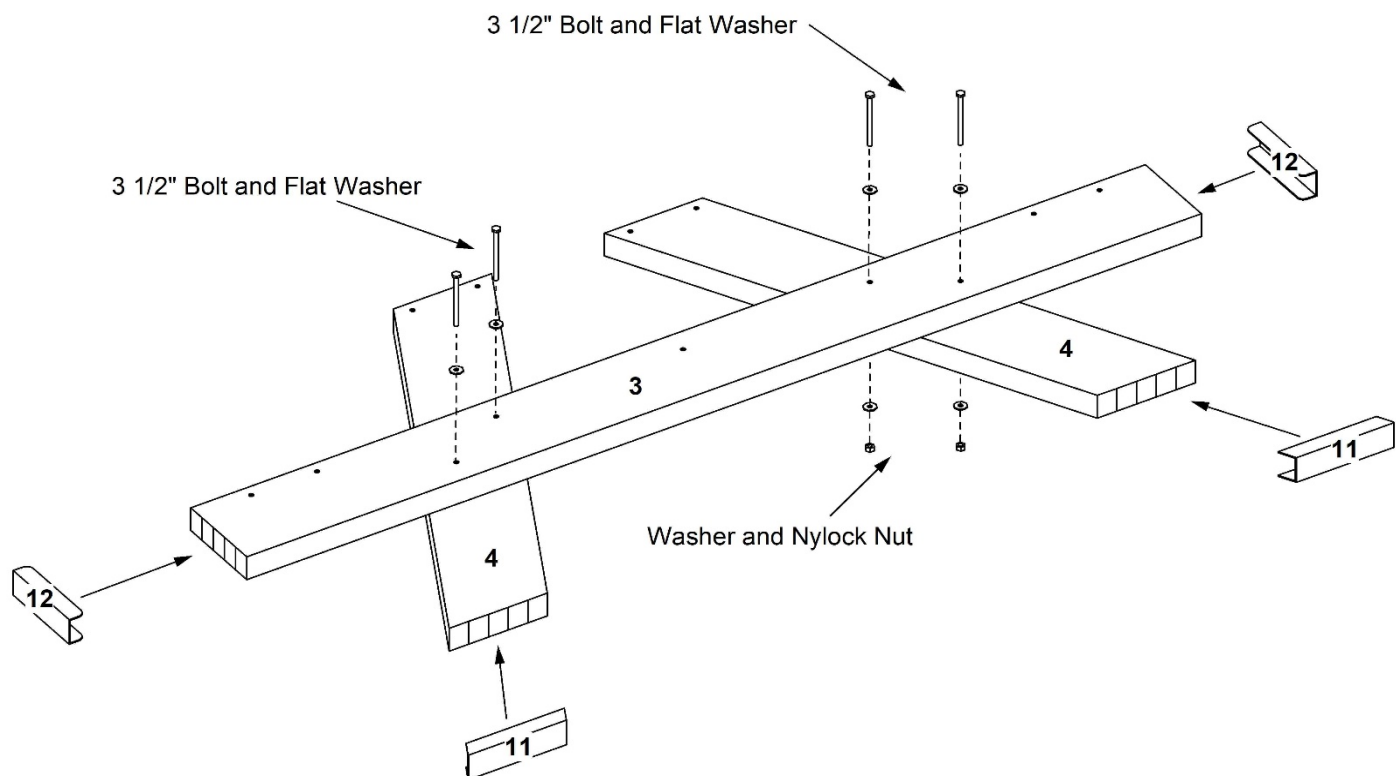

CROSS BRACE / LEG ASSEMBLY

Lay out two 30 $\frac{1}{4}$ " legs (part 4) on an angle with pre-drilled holes for attaching table top, nearest each other at top. Lay one 59 $\frac{1}{2}$ " cross brace (part 3) across legs; adjusting legs so bolt holes line up.

Using four 3 $\frac{1}{2}$ " bolts, eight washers and four nuts, fasten cross brace to legs. (Do not over tighten as this will crush the vinyl) Bolt heads will face outside of the table.

Apply glue to inside edges of 5 $\frac{1}{2}$ " cross brace end cap (part 12). Press end cap onto ends of cross brace (DO NOT slide from end). Take care that end cap is flush with ends and use a file to round off any sharp edges.

Apply glue to inside edges of 6 $\frac{1}{8}$ " seat end cap (part 11). Press end cap onto ends of seat (DO NOT slide from end).

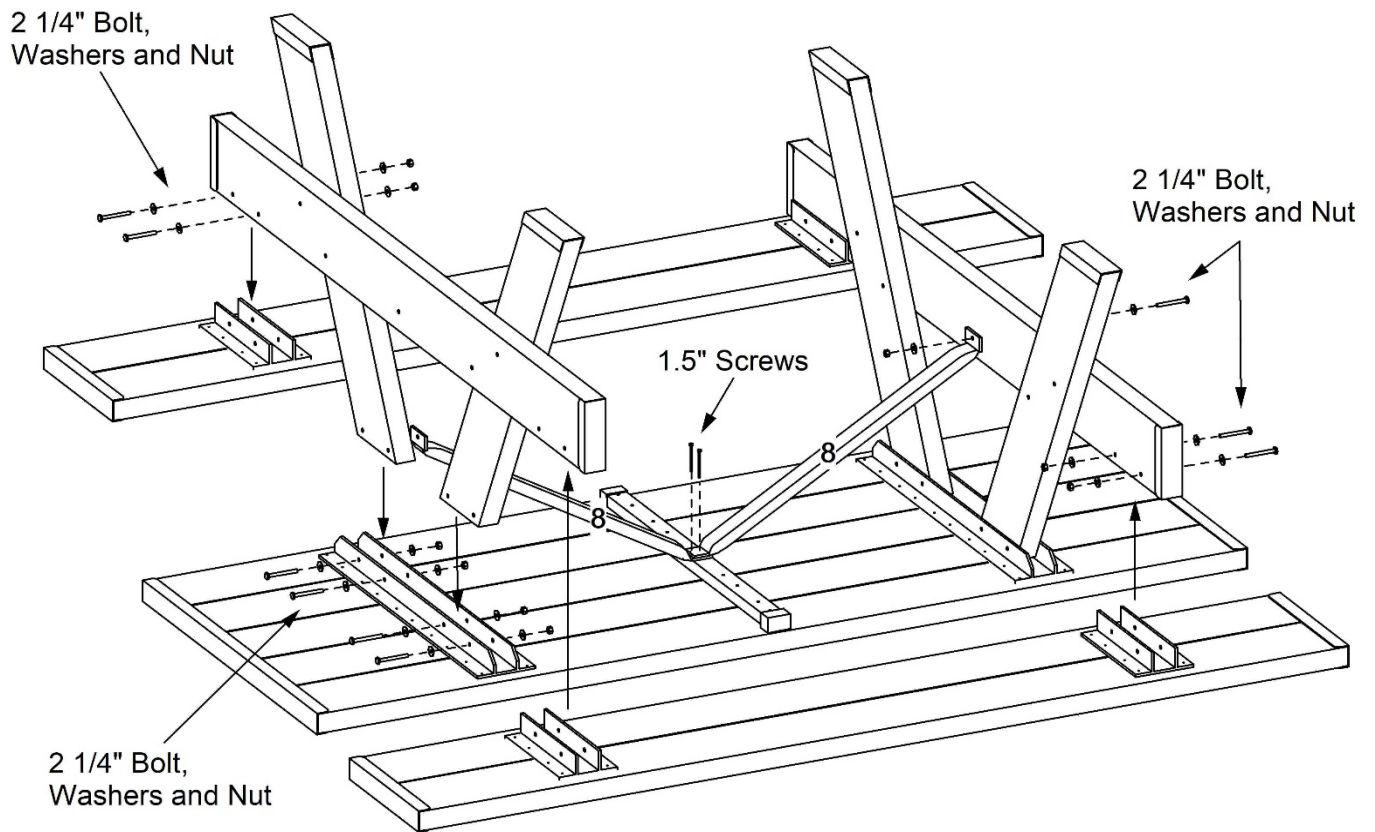

Insert one cross brace / leg assembly into brackets on underside of table top with cross brace closest to table end. Using four 2¼" bolts, washers and nuts, fasten assembly to table top. Repeat with second cross brace / leg assembly for opposite end of table.

Using one 2¼" bolt, washers and nut, bolt one 33½" diagonal brace (part 8) to center of each cross brace. In center of table, overlap free ends of diagonal braces and drill two ⅛" holes through braces and into center brace. Using two 1½" screws, fasten both diagonal braces to center brace.

Position seat assemblies over cross braces and line up bolt holes of brackets to holes in cross brace. Using four 2¼" bolts, washers and nuts per seat assembly, fasten seat assembly to cross brace.